

# iFlex Single Traffic Barrier+ Cold Storage

A-SAFE iFlex Cold Storage Single Traffic Barrier+ is designed to protect people, buildings and infrastructure from impacts with forklifts and other vehicles. This high-strength dual-function barrier has been purpose-engineered for applications within sub-zero environments such as cold storage facilities. It delivers supreme performance in temperatures as low as -30°C.

Manufactured from Memaplex™ Sub-Zero, a unique blend of polymers designed to withstand multiple impacts without cracking or fragmenting, iFlex Cold Storage Single Traffic Barrier provides both guidance and physical protection.

A heavy-duty traffic rail provides robust resistance against vehicle impacts, while an ergonomic handrail increases the height of the barrier to segregate pedestrian walkways and prevent falls. Ideal for busy sub-zero environments where people and vehicles share space.



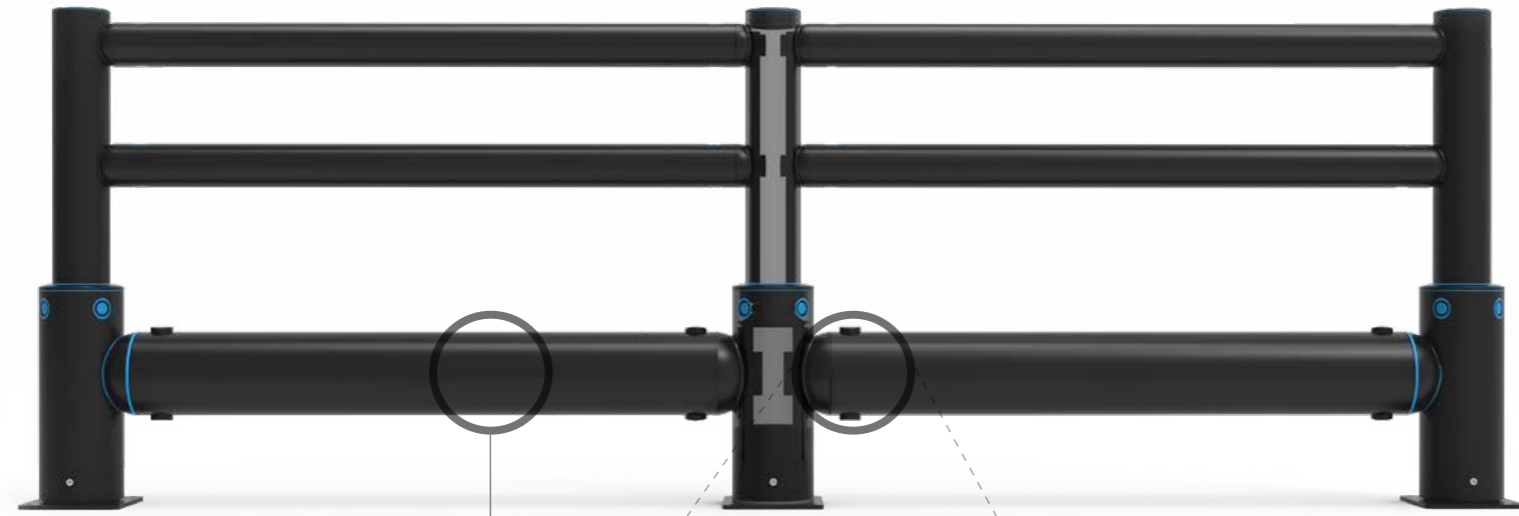

## MEMAPLEX™

**Ultimate strength polymer**  
created from an exclusive composition of the most sophisticated polyolefins and rubber additives, expertly blended for unequalled strength and flexibility.

**Advanced Engineering Molecular**  
reorientation during manufacturing creates a unique built-in memory that enables the barrier to fully recover following impacts.

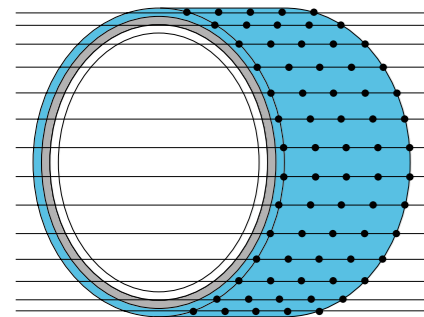

### Revolutionary 3-Layered Material

- Inner strengthening core
- Central impact absorption zone
- Outer UV stabilised colour layer

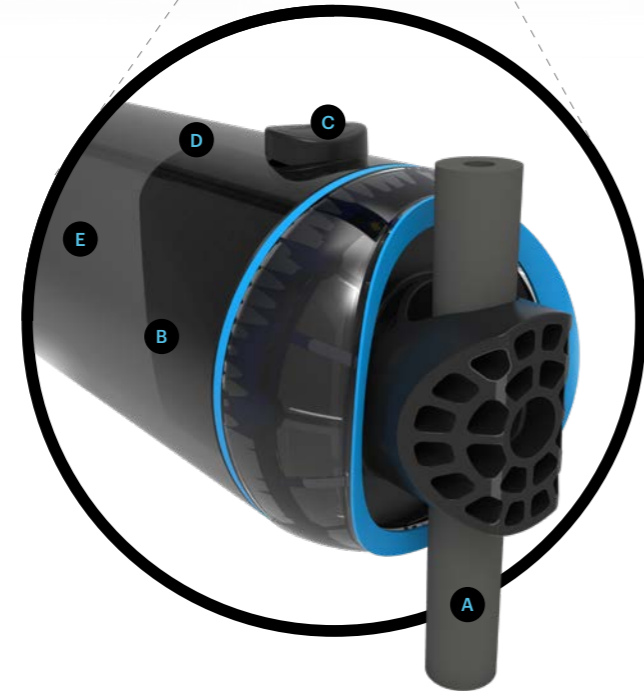

## Energy Absorption System

A patented 3-phase system that activates sequentially for unparalleled energy absorption.

- 1 Memaplex™ rail flexes to absorb impact, initiating the rail pin to slide forward and transfer load energy to the compression pocket.
- 2 Compression of the pocket continues to disperse energy as the coupling rotates around the post pin to activate further absorption.
- 3 At peak energy, the coupling twists further, engaging the post pin and instigating torsion of the post to dispel remaining forces.

- A** Post Pin
- B** Coupling
- C** Rail Pin
- D** Compression Pocket
- E** Rail

## Suitability

Vehicle

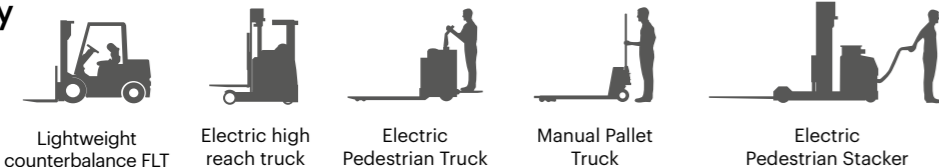

Application

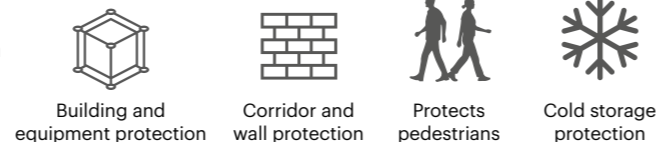

Unrivalled recovery through a unique built-in memory that allows the barrier to flex, cushion and reform repeatedly upon impact, saving vast amounts in barrier and vehicle repairs.

Huge return on investment from incident prevention and downtime avoidance as barriers, vehicles, floors and equipment do not need replacing or repair.



## Features and benefits



Multi-directional system ensures a streamlined fit into any operation and the removal of hard angles.



Zinc nickel, electroplated coating on base plates as standard, provides advanced protection against corrosion damage.



Exclusive modularity allows rails and posts to be replaced in-situ without removing adjacent barrier sections.



Hygiene seals remove ingress points.



Ultra-low maintenance material is chemical and water resistant, non-corrosive, non-scratch and self coloured so no repainting, rusting, flaking or corrosion.



Self coloured and UV stabilised for continued visibility and long lasting aesthetics with no repainting.



No floor damage 80% of impact force is absorbed, transferring just 20% to the floor.

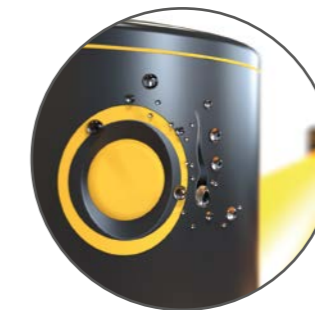

Food safe, wipe-clean, water resistant surface.



Ergonomic design with no sharp edges.



Environmentally friendly and 100% recyclable.



# Technical Information

How the energy from a vehicle impact is calculated

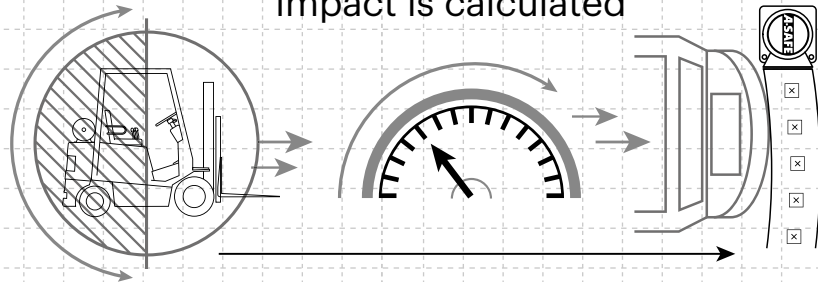

$$\frac{1}{2} \text{ Mass} \times \text{Speed}^2 = \text{Joules}$$

**Tested Impact Energy**

**30,200 Joules**

Equivalent vehicle and speed

**8.4 tonne** X **6 mph impact**

Mid Rail 45° Impact on 2000mm Post Centres

Dimensions (mm)

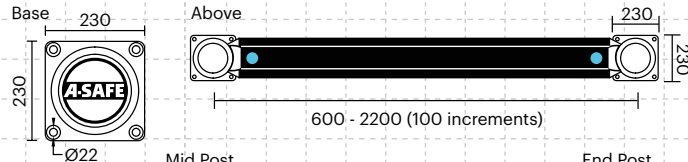

X = Impact Zone  
205 - 395mm

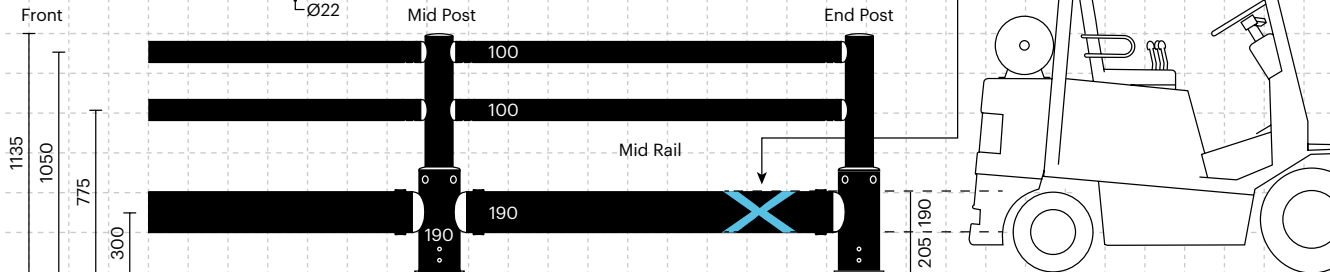

Impact Test	Impact Angle on 2000mm Post Centres			
	90°	67.5°	45°	22.5°
Mid Rail Max Energy (Joules)	15,100	17,691	30,200	103,109

End Post Max Energy (Joules) - 90°	6,900
Mid Post Max Energy (Joules) - 90°	6,900

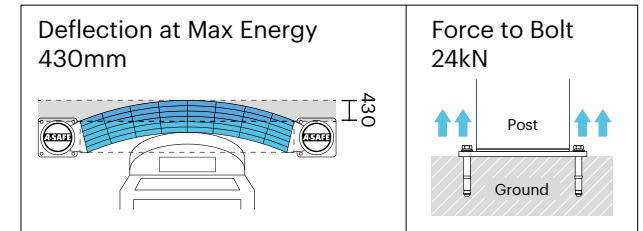

Material Properties	MEMAPLEX™
Temperature Range	-30°C to 0°C
Ignition Temperature	370°C to 390°C
Flash Point	350°C to 370°C
Toxicity	Not Hazardous
Chemical Resistance	Excellent - ISO/TR 10358
Weathering Stability (Grey Scale)	5/5*
Light Stability (Blue Wool Scale)	7/8**
Static Rating (Surface Resistivity)	1015 - 1016 Ω
Hygiene Seals	Yes

## Post



## Rail

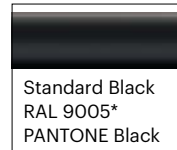

## Colour

\*Please note that the RAL and PANTONE colours listed are the closest match to standard A-SAFE colours, but may not be exact matches of the actual product colour and should be used for guidance only.

\* Weathering scale 1 is very poor and 5 is excellent

\*\* Light stability scale 1 is very poor and 8 is excellent

